

DAVI

MCB 4 Roll



Mission

01

We work hard to be the partner of choice whenever companies need to roll Metal Plates and Sections. We strive to be by the customers' side for any rolling work they have to carry on.

02

This goal has deep roots in the past, with the rolling challenges we overcame in our history since 1966, studying the specific needs of customers and finding the best way to go on together.

03

This goal is very clear in the present: our daily task is to support our current customers and to invest in research and development for being at the forefront of rolling innovation.

04

This goal sets clear projects for the future: our financial strength and our solid structure grant the continuity of our business and the support we will be able to give in terms of both service and new solutions.

DAVI

Davi is since more than a decade the world largest manufacturer of Plate Rolls, Angle Rolls, High Productivity Lines and Customized Rolling Machines in terms of sales volume, employees, range, production, assets and rating. In fact, Davi has been awarded 'Prime Company' and given maximum commercial reliability by Dun & Bradstreet and holds all the ISO Certifications (Quality ISO 9001, Environmental ISO 14001, Safety ISO 45001).

Since 1966, Davi has been committed in Research & Development with the goal of finding the best Rolling Solutions for the global market.

Davi headquarters are located in Italy, where all Plate and Angle Rolls are manufactured and then delivered all around the world, while the Sales & Service network is comprised of two branches in the United States and China and more than a hundred dealers in the five continents.



MCB - 4 Roll Plate Rolling Machine

Whenever repeatability, productivity
and ease of use are of essence, the 4-roll
is the technology of choice



EXTREME
iRoll

**The new Frontier
of Control System**

Ergonomic console and
high-res interface for a
throughput maximized
thanks to Davi AI
(Artificial Intelligence)

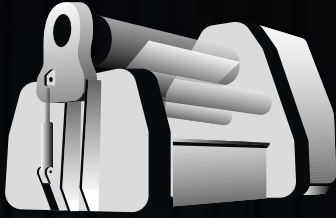

Shortest Flat End

thanks to sturdy and closed frame

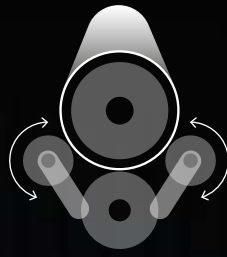

Tightest Achievable Diameters

thanks to Planetary Guides

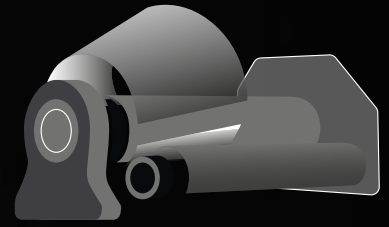

Higher Tilting Capacity

thanks to pendular Gearboxes arrangement



Best Rolls Parallelism

thanks to patented Servo-Tronic® system

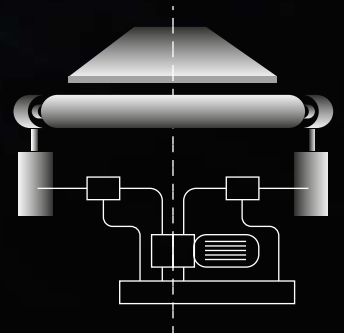

Great Operability and Maintainability

thanks to the new design of the machine

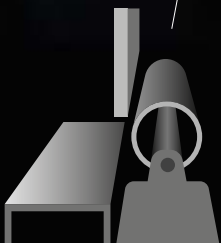

Plate Roll Ready for Upgrade

thanks to the highest level of Customization on the market

Shortest Flat End

Sturdy, compact and closed frame to guarantee machine stability, minimize deflections and for a much shallower pit.

The frame constitutes, effectively, the back-bone of the machine. The stress generated during plate forming must be withstood by this critical component and, eventually, transmitted to the foundations. This sturdy and closed frame is one of the main features guaranteeing Davi MCB to obtain the shortest flat end.

Davi machines feature the most compact and closed frame on the market, which allows to improve the rigidity of connection to the ground as well as machine stability, and construct a much shallower and less expensive pit, due to reinforcement beams installed between frames (intra-frame design) rather than base platform.

Based on extensive Finite Element Method (FEM) studies conducted by Davi R&D, it is observed that the frame is particularly under stress while pre-bending. Davi exclusive design features a much higher rigidity of the overall structure hence guaranteeing maximum accuracy even in the most demanding pre-bending and re-rolling operations.



Tightest Achievable Diameters

The bending power of a 4-roll machine is exerted to the plate by two side rolls. Unlike other solutions on the Market, Davi exclusive design provisions a planetary actuation of the side rolls whereas, rather than being guided up and down, the mechanism rotates around a pivoting point.

Thanks to this system Davi MCB grants maximum performance thanks to force multiplier effect by leverage arm (distance between pivoting point and cylinder force application point), a reduced top-roll deflection due to circular force application and forming the tightest diameters thanks to favorable geometry (with side rolls wrapping around small diameters cans).





Best Rolls Parallelism and Higher Tilting Capacity

The patented Servo-Tronic® system keeps the machine's rolls parallel at all times thanks to its dual, independent but integrated, parallelism control system. This system features dedicated pumping groups and circuits guaranteeing that each cylinder receives oil at the very same pressure and mass flow, with electro-valves for fine-tuning only.

In this way, even in case of electronics failure, the rolls parallelism is hydraulically and mechanically maintained and the machine can keep operating with excellent results.

Davi pendular shaft-mounted gearboxes configuration allows for stress-free tilting of the rolls up to 100 mm every 3 meters rolls length.

Best Operability and Maintainability

The improved design of the machine allows for increased operability during the whole process, provisioning a reinforced yoke with large pivoting points for reducing the top-roll deflections and compact frames to easily eject the formed workpiece and to make extreme cones with no interference.

The planetary guides significantly reduce the required machine maintenance, thanks to no need for regular lubrication with friction free movements and maximum energy efficiency and durability with eliminated risk of guides wearing on accumulated mill-scale.



Upgrades

Davi MCB machines are equipped with state-of-the-art control systems, specifically designed by Davi R&D Department to help you getting the most out of your 4-roll plate rolling machine.

Even the small and medium capacity machines solutions can be fully customized to better support the most diverse production requirements and industrial sectors.

Thanks to Davi Industry 4.0 CNC, all operators, even the most inexperienced ones, will finally have the capacity to comply with the required tolerances with maximum repeatability: a real boost to your competitiveness.

Moreover, all Davi CNC systems are expandable to allow retrofitting of auxiliary equipment (such as vertical and side supports, gantry loaders, etc.) at any time.



Customer support

Remote Support

Davi Specialized Team can connect remotely with every corner of the world and improve the customer's uptime



On Site

On site intervention can be performed on both Davi Machines and other brands: from Installation to Commissioning, from Training to Preventive Maintenance



Production in numbers



100

Plate and Angle
Rolls always
available and
ready for delivery

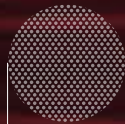

300

Plate and Angle
Rolls produced
every year

10,000

More than 10,000
Plate and Angle
Rolls installed
worldwide

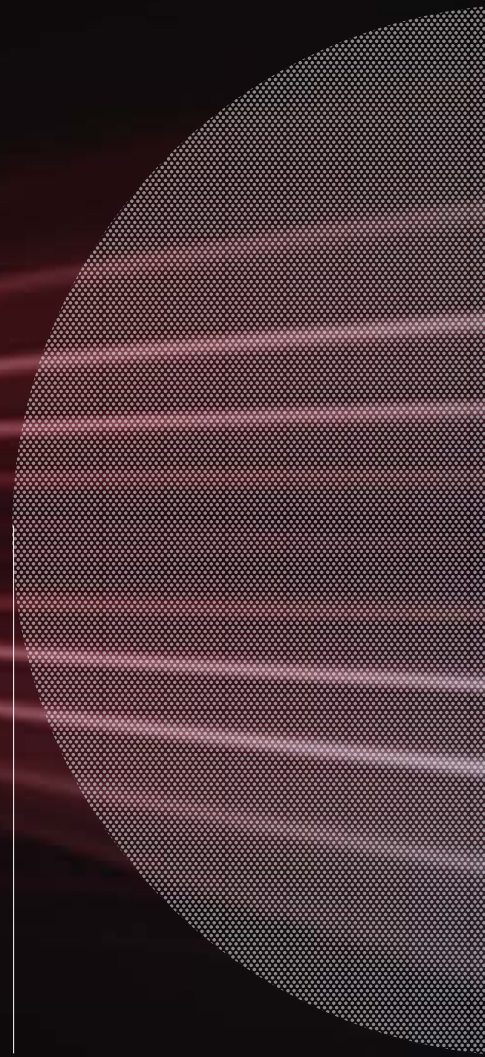



Research & Development

Engineering Everyday Challenges

Davi Sales and Technical Teams are always ready to exchange ideas with Customers, in order to get a full comprehension of the Rolling Challenge they have to face. Davi R&D wants more, and strives to offer innovative solutions to problems customers didn't even think of!





Total Control of the Production System

In order to obtain Complete Management on the whole Manufacturing Process, for many years Davi has created a solid partnership with Suppliers, High-level Companies with production sites in the most skilled areas of Italy.

Throughout the entire flow, Davi is committed to ensure an Integrated Quality Control with the aim of ensuring the highest quality standards on the Market.



EN 07/23

DAVI

www.davi.com

DAVI - PROMAU SRL
via Cavinelli, 1150 - 47522 Cesena (FC) Italy
T: +39 0547 319611 - davi-sales@davi.com

DAVI INC.
15107, Surveyor Boulevard, Addison, TX - 75001
Ph. (972) 661-0288 - davi-inc@davi.com

DAVI SHANGHAI
中国上海市闵行区古北路1699号1608室
电话: +86 21 6488 3162 - davi-shanghai@davi.com

